

HANCOR CHANNEL-FLOW® PIPE SPECIFICATIONS

Scope

This specification describes Hancor Channel-Flow pipe in 4-inch (100 mm) diameter for use in on-site waste applications.

Pipe Requirements

Hancor Channel-Flow pipe shall meet the requirements of ASTM F405 and SCS 606. It shall have a corrugated interior and corrugated exterior. Perforations shall be spaced every 4.2-inches (107 mm) on the length of the pipe.

Joint Performance

Pipe shall be joined with self-coupling stubs located at the ends of each pipe section.

Fittings

Fittings shall conform to ASTM F405.

Material Properties

Pipe material shall be high density polyethylene conforming with the minimum requirements of cell classification 424410C as defined and described in the latest version of ASTM D3350; or ASTM D1248 Type III, Class C, Category 4, Grade P33.

Installation

Installation shall be in accordance with ASTM F481 and those issued by the local health department.

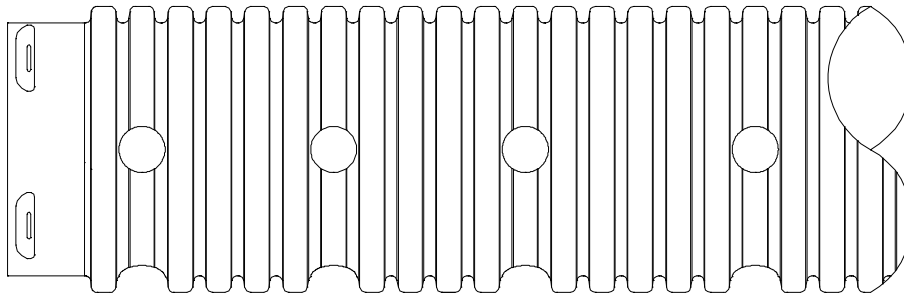

Perforation Options*

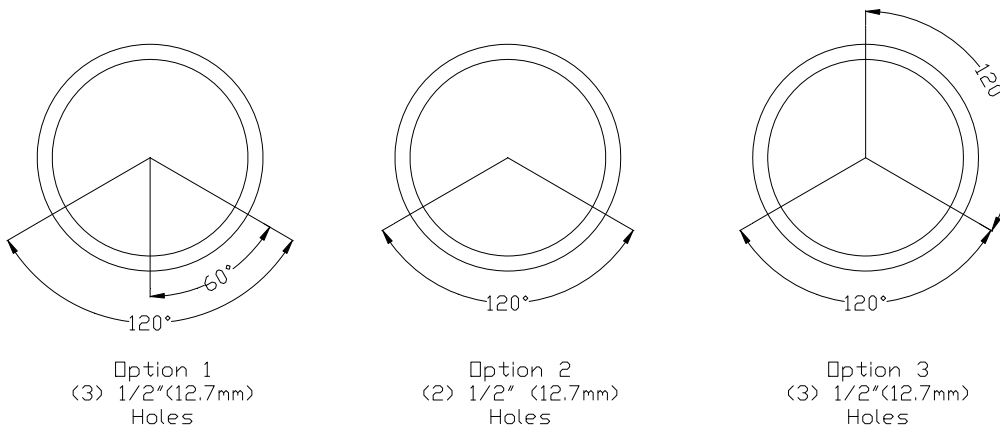

* Check with sales representative for perforation option availability by region.