

HANCOR METER PIT SPECIFICATION

Scope

This specification describes 18-, 21-, and 24-inch (450, 525, and 600mm) Meter Pit for use as meter enclosures.

Requirements

Hancor Meter Pits shall be white in color. Meter pits shall have a smooth interior and annular exterior corrugations. Based on ASTM D 2412 at 5% deflection the pipe stiffness for 18-inch (450 mm), 21-inch (525 mm), and 24-inch (600 mm) Meter Pits shall be 40 pii (275 N/m/mm), 34 pii (235 N/m/mm), and 34 pii (235 N/m/mm), respectively. The pits shall be available in 24, 30, 36, 48 inch, and 12 foot (0.6, 0.8, 0.9, 1.2, and 3.7 m) lengths. Meter Pits shall be notched at 0 and 180 degrees at the base to accommodate inlet and outlet pipes.

Material Properties

Meter pits shall be high density polyethylene conforming with the minimum requirements of cell classification 424420 B as defined and described in the latest version of ASTM D3350.

Installation

Installation shall be in accordance with Hancor installation instructions or those issued by regional, state, or local agencies.

Nominal Dimensions

Inner Diameter	in (mm)	18 (450)	21 (525)	24 (600)
Outer Diameter	in (mm)	21.5 (546)	25 (635)	28.4 (721)

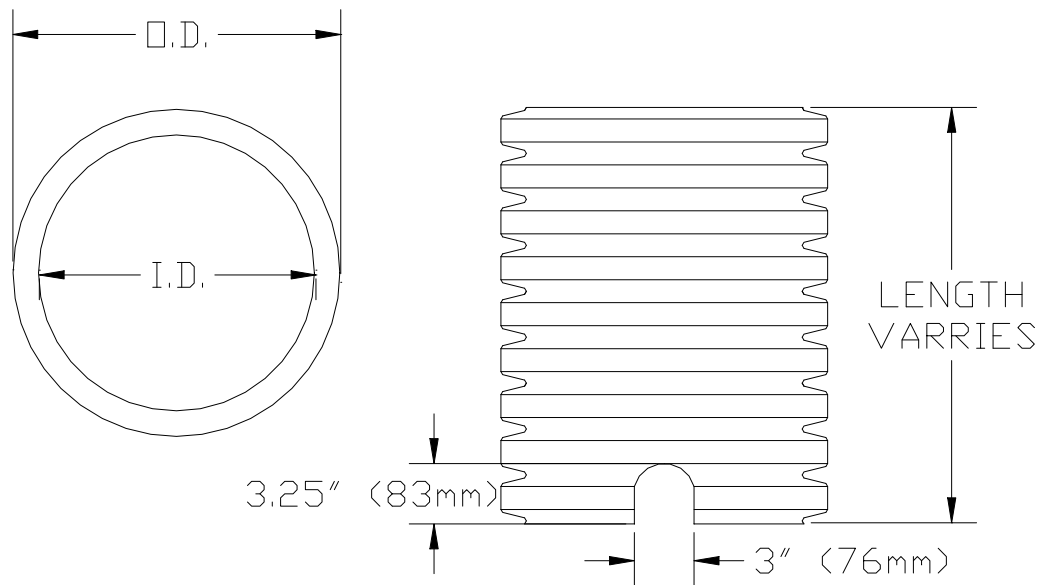

Warning: This product is not supplied with a grate or lid for means of termination at the ground surface. It is the sole responsibility of the installer/user of this product to adequately insure the product has been covered and secured at the top of the structure/product. Poor installation or failure to adequately cover and secure this product may result in injury to persons and property.