



# INSTALLATION GUIDE

Storm Water Quality Units

IG 2.01  
October 2008

Hancor polyethylene products and a well-constructed backfill envelope work together to support soil and live loads. Although backfill has special significance in applications involving high loads, it is important to take reasonable precautions during any pipe installation. Correct installation will ensure long-term trouble-free service for all types of pipe systems.

The recommendations presented here detail how to correctly install Storm Water Quality Units. Installation with proper backfill materials, compaction levels, and placement procedures are essential to achieve long term system performance. These recommendations assume the drainage designer used design criteria available from ASTM D2321 and Hancor. The designer should discuss installations involving conditions not covered by that document (poor soils, high loads, or other factors that may affect the performance of the system) with Hancor Regional Engineers or Application Engineering through the nearest manufacturing location.

## Backfill Material Selection

- Structural backfill material must be a Class I material described in Table 1.
- Native soil meeting class II, III, or IVA, as described in Table 1, are NOT acceptable initial backfill materials. However, they may be used as final backfill once the initial backfill is placed and compacted.
- Class I materials shall be compacted to a minimum Standard Proctor Density of 95%.
- In regions where Class I backfill material may not be readily obtainable, flowable fill may be a suitable alternative. Where flowable fill is used, precaution must be taken to prevent flotation during installation.

**Table 1**  
**Acceptable Backfill Material and Compaction Requirements**

Description	Soil Classification		Minimum Standard Density (%)	Maximum* Compaction Layer Height (in.)
	ASTM D2321	ASTM D2487		
Flowable Fill	n/a	n/a	Dumped	**
Graded or crushed stone Crushed gravel	Class I	-	Compacted	12 (0.3m)
Well-graded sand, gravels, and gravel/sand mixtures; Poorly graded sand, gravels and gravel/sand mixtures; little or no fines	Class II	GW GP SW SP	<b>Material Not Recommended</b>	
Silty or clayey gravels, Gravels/sand/silt or gravels and/clay mixtures, silty or clayey sands, sand/clay or sand/silt mixtures	Class III	GM GC SM SC	<b>Material Not Recommended</b>	
Inorganic silts and low to medium plasticity clays; gravelly, sandy, or silty clays; some fine sands	Class IVA	ML CL	<b>Material Not Recommended</b>	
*Layer Heights should not exceed one-half the pipe diameter. Layer heights may also need to be reduced to accommodate compaction method.				
**Where flowable fill is used, precaution must be taken to prevent flotation.				

*NOTE: These recommendations are general in nature and are not meant to be specific. Consult a geotechnical engineer for project specific design and installation recommendations.*



# Trench Construction

- Trench or ditch should be just wide enough to place and compact backfill around the entire pipe. A minimum width of OD + 36" but no greater than OD + 72" is recommended. *Trench width does not account for the bypass pipe, this estimate is for the main unit only.*
- As with any pipe, groundwater or seasonal high water tables may impede installation. De-watering is necessary for safe, efficient installation.
- Trench or ditch bottoms containing bedrock, soft muck or refuse, or other material unable to provide long-term pipe support are unacceptable.
- If a firm foundation is exposed, replace excavated material with acceptable backfill and compact as shown.
- Remove rock or unyielding material 1-foot (0.3m) below grade and 6" (0.15m) on either side of pipe.\*
- Excavate soft areas approximately 2 feet (0.6m) below grade and three times pipe width.\*
- If soft area remains after excavation or if native soil can migrate into backfill, use synthetic fabric (geotextile) to separate native soil from backfill.\*
- For a flat bottom trench, the middle of bedding equal to 1/3 the pipe OD shall be loosely placed while the remainder shall be compacted in accordance with Table 1.

HANCOR UNIT SIZE	MINIMUM D	MINIMUM W
36" (900mm)	4.5 (1.37M)	6.5 (1.98M)
42" (1060mm)	5.0 (1.52M)	7.0 (2.13M)
48" (1200mm)	5.5 (1.68M)	7.5 (2.29M)
60" (1500mm)	7.5 (2.29M)	8.5 (2.59M)

\* DOES NOT ACCOUNT FOR BYPASS PIPE. THIS ESTIMATE IS FOR THE MAIN UNIT ONLY

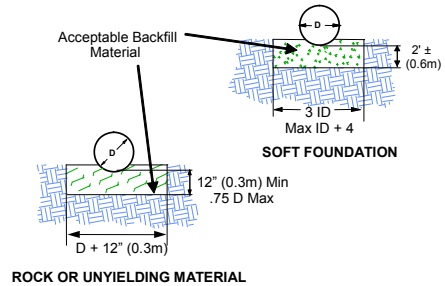
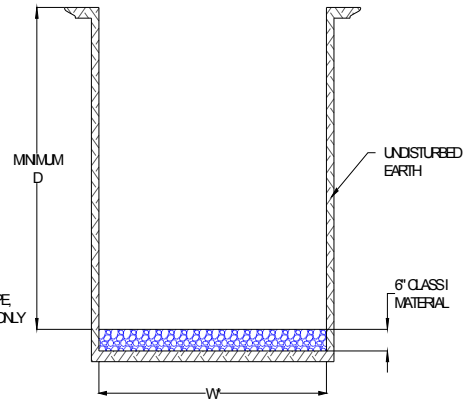

\*These recommendations are general in nature and are not meant to be specific. Consult a geotechnical engineer for project specific design and installation recommendations

# Backfill Envelope Construction

## Placing Unit and Initial Backfill

- Utilize care when lowering unit into the trench. Handle using nylon slings and two pick points. Do not use slings around risers.
- Place and compact Class I backfill in layers to meet requirements of Table 1.
- When the unit consists of two sections, place the downstream section first. Properly lube the bell and spigot to connect and home the remaining section.

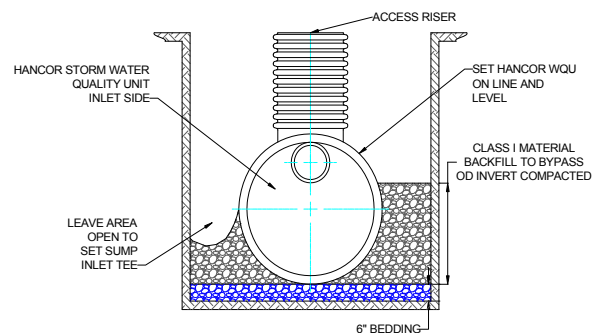



## Connecting the Bypass

- Start on the downstream end by connecting the outlet fitting – be sure to match the inverts of the unit outlet and bypass pipe.
- The bypass pipe of the Hancor SWQU is designed to convey the peak storm water flow of the storm line. For example, at a 1% slope, peak flow rates for the bypass are as follows:

Diam. (in)	CFS	L/S	Diam. (in)	CFS	L/S
12	4	100	36	72	1900
15	7	190	42	110	2900
18	11	300	48	160	4200
24	24	660	60	280	7600
30	44	1200			

- Bypass fittings can be connected using the same couplers as the main storm sewer pipe. Couplers may be split couplers, gasketed split couplers, bell-bell couplers or welded couplers.

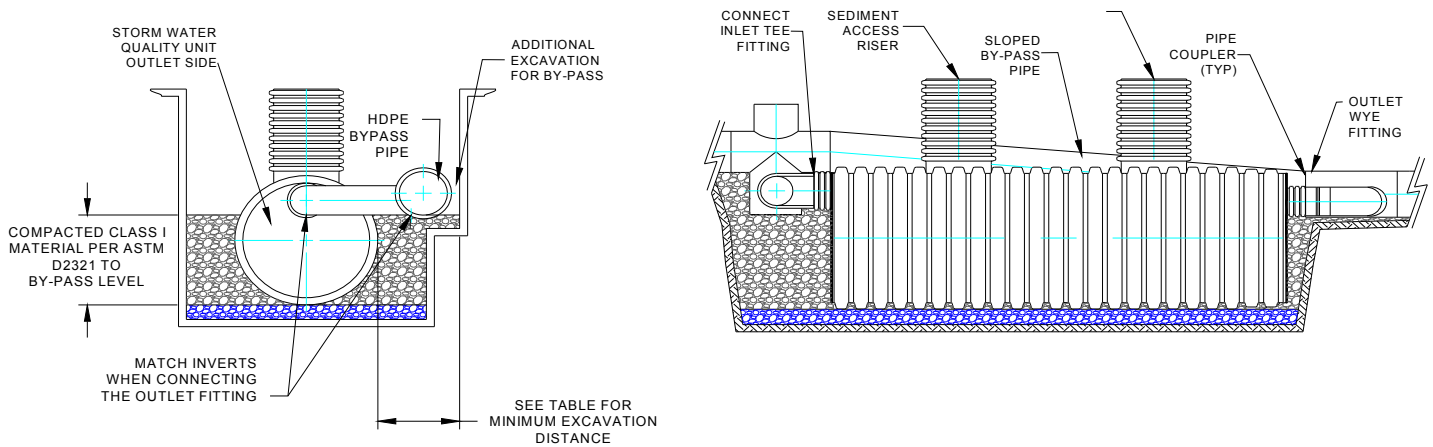

- Place and compact initial backfill in layers around pipe to at least 12" (0.3m) above the crown as shown.
- Avoid impacting pipe or separator unit with compaction equipment.

## Backfill Around the Unit and Bypass

- Distance from outside diameter of SWQU (trench side) to bypass outer trench wall are provided in the following table (see detail above for distance reference):

Bypass Pipe Diameter, in (mm)								
12 (300)	15 (375)	18 (450)	24 (600)	30 (750)	36 (900)	42 (1050)	48 (1200)	60 (1500)
41 (1041)	44 (1118)	49 (1245)	56 (1422)	64 (1626)	71 (1803)	78 (1981)	85 (2159)	100 (2540)

- Continue backfill with Class I material to 12" above the Water Quality Unit (24" for 60" units).
- Place and compact initial backfill in layers around pipe to at least 12" (0.3m) above the crown.



- Avoid impacting pipe or separator unit with compaction equipment.
- Final backfill and compaction should be appropriate for anticipated loading.
- Fill unit with water to the top of the sediment weir plate once backfill is placed and compacted 12" above the unit.

## Final Cover and Riser Extensions

- For non-traffic loading, H=12" for 36", 42", and 48" units measured from the top of the unit to the bottom of bituminous pavement or top of rigid pavement. H=24" for 60" units.
- For traffic loading, H=24" for 36", 42", and 48" units measured from the top of the unit to the bottom of bituminous pavement or top of rigid pavement.
- If sufficient cover is provided, no further precautions are required.
- If sufficient cover is not provided, mound and compact material over pipe to provide minimum cover needed for load during construction. Final backfill and compaction should be appropriate for anticipated loading.

