



INSTALLATION GUIDE

Grease Interceptor

IG 2.04
March 2008

The recommendations presented here detail how to correctly install Grease Interceptors. Installation with proper backfill materials, compaction levels, and placement procedures are essential to achieve long term system performance. These recommendations assume the drainage designer used design criteria available from ASTM D 2321 and Hancor. The designer should discuss installations involving conditions not covered by that document (poor soils, high loads, or other factors that may affect the performance of the system) with a Hancor representative. All installations must comply with local state and federal regulations.

Backfill Material Selection

- Structural backfill material must be a Class I material described in Table 1.
- Native soil meeting class II, III, or IVA, as described in Table 1, are **NOT** acceptable initial backfill materials. However, they may be used as final backfill once the initial backfill is placed and compacted.
- In regions where Class I backfill material may not be readily obtainable, flowable fill may be a suitable alternative. Where flowable fill is used, precaution must be taken to prevent flotation during installation.

Table 1
Backfill Material and Compaction Requirements

Description	Soil Classification		Minimum Standard Density (%)	Maximum* Compaction Layer Height (in.)
	ASTM D2321	ASTM D2487		
Flowable Fill	n/a	n/a	Dumped	**
Graded or crushed stone Crushed gravel	Class I	-	Compacted	12 (0.3m)
Well-graded sand, gravels, and gravel/sand mixtures; Poorly graded sand, gravels and gravel/sand mixtures; little or no fines	Class II	GW GP SW SP	Material Not Recommended	
Silty or clayey gravels, Gravels/sand/silt or gravels and/clay mixtures, silty or clayey sands, sand/clay or sand/silt mixtures	Class III	GM GC SM SC	Material Not Recommended	
Inorganic silts and low to medium plasticity clays; gravelly, sandy, or silty clays; some fine sands	Class IVA	ML CL	Material Not Recommended	
*Layer Heights should not exceed one-half the pipe diameter. Layer heights may also need to be reduced to accommodate compaction method.				
**Where flowable fill is used, precaution must be taken to prevent flotation.				

NOTE: These recommendations are general in nature and are not meant to be specific. Consult a geotechnical engineer for project specific design and installation recommendations.



Trench Construction

- Trench or ditch should be just wide enough to place and compact backfill around the entire Grease Interceptor. A minimum width of OD + 36" but no greater than OD + 72" is recommended.
- As with any underground structure, groundwater or seasonal high water tables may compromise proper installation. De-watering is necessary for a safe and effective installation.

UNIT SIZE	MINIMUM D	MINIMUM W*
48"	6.5'	7.5'
60"	7.5'	8.5'

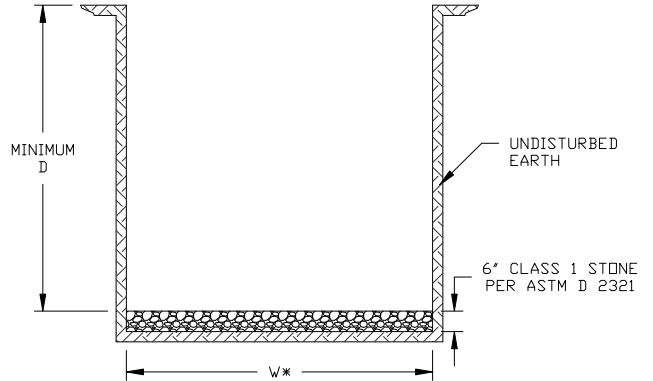

- Trench or ditch bottoms containing bedrock, soft muck or refuse, or other material unable to provide long-term pipe support are unacceptable.
- If a rock foundation is exposed, excavate this material to the specified depth and replace with acceptable backfill material and compact as shown.
- Remove rock or unyielding material 1-foot (0.3m) below grade and 6" (0.15m) on either side of pipe.*
- Excavate soft areas approximately 2 feet (0.6m) below grade and three times pipe width.*
- If soft area remains after excavation or if native soil can migrate into backfill, use synthetic fabric (geotextile) to separate native soil from backfill.*
- For a flat bottom trench, the middle of bedding equal to 1/3 the pipe OD shall be loosely placed while the remainder shall be compacted in accordance with Table 1.

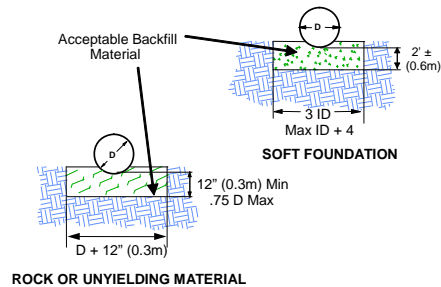

These recommendations are general in nature and are not meant to be specific. Consult a geotechnical engineer for project specific design and installation recommendations

Backfill Envelope Construction

Placing Unit and Initial Backfill

- Utilize care when lowering unit into the trench. Handle using nylon slings and two pick points. Do not use slings around risers.
- Place and compact Class I backfill in layers to meet requirements of Table 1.

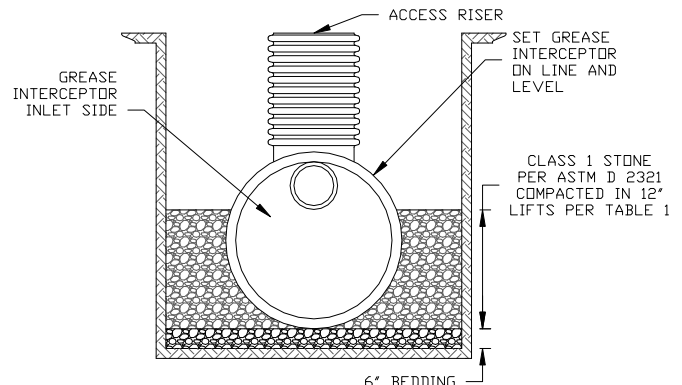

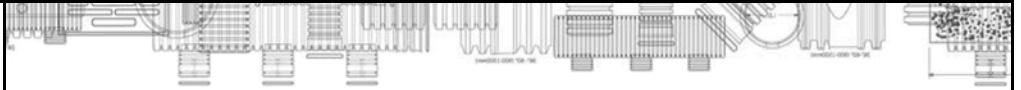

Inlet/Outlet Connections

- Start on the downstream end by connecting the outlet to the sewer line with the appropriate coupler called for on the plans. End plates will have "inlet" and "outlet" stenciled for recognition.
- Couplers connecting the inlet and outlet shall have the same joint performance as the sewer line. Couplers may be rubber boots or PVC to HDPE adapters as called for on the plans.
- For venting, install tap connections (inserta tee or Uni-T) in riser section and extend using pipe and fittings as prescribed in the plans.
- Avoid impacting Grease Interceptor unit with compaction equipment.

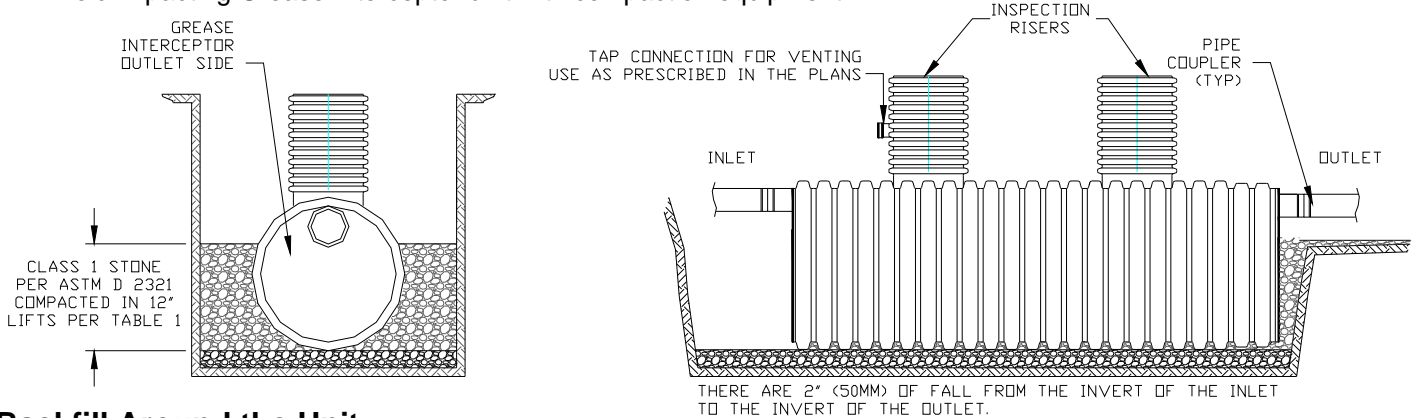

Backfill Around the Unit

- Continue backfill with Class I material as per Table 1.
- Place and compact initial backfill in layers around pipe to at least 12" (0.3m) above the crown as shown.
- Avoid impacting Grease Interceptor unit with compaction equipment. If impacted, inspect unit to ensure it has not been damaged.
- Final backfill and compaction, measured from 12" (300mm) above the unit to final grade, is to be done per the engineer's specification for anticipated loading.
- Fill unit with water to invert of the outlet pipe once backfill is placed and compacted 12" above unit.

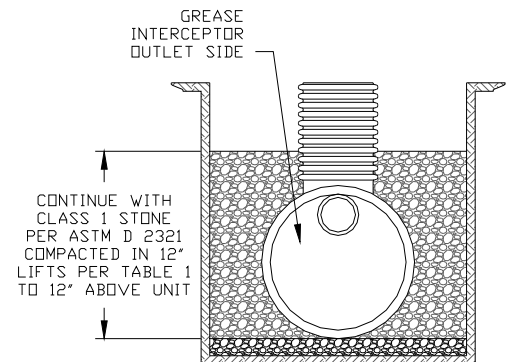

Final Cover and Riser Extensions

- For non-traffic and traffic loading, H=24" measured from the top of the unit to the bottom of bituminous pavement or top of rigid pavement. Maximum cover shall not exceed 96".
- If sufficient cover is provided, no further precautions are required.
- If sufficient cover is not provided, mound and compact material over Grease Interceptor to provide minimum cover needed for load during construction. Final backfill and compaction should be appropriate for anticipated loading.
- For traffic loading, all inspection risers shall have a traffic rated lid and load beading concrete collar. Nyloplast[®] in-line drains must be supported by a concrete collar so the traffic load is not transferred directly to the HDPE riser.

